

# BALL VALVE PARTS

## THREE PIECE

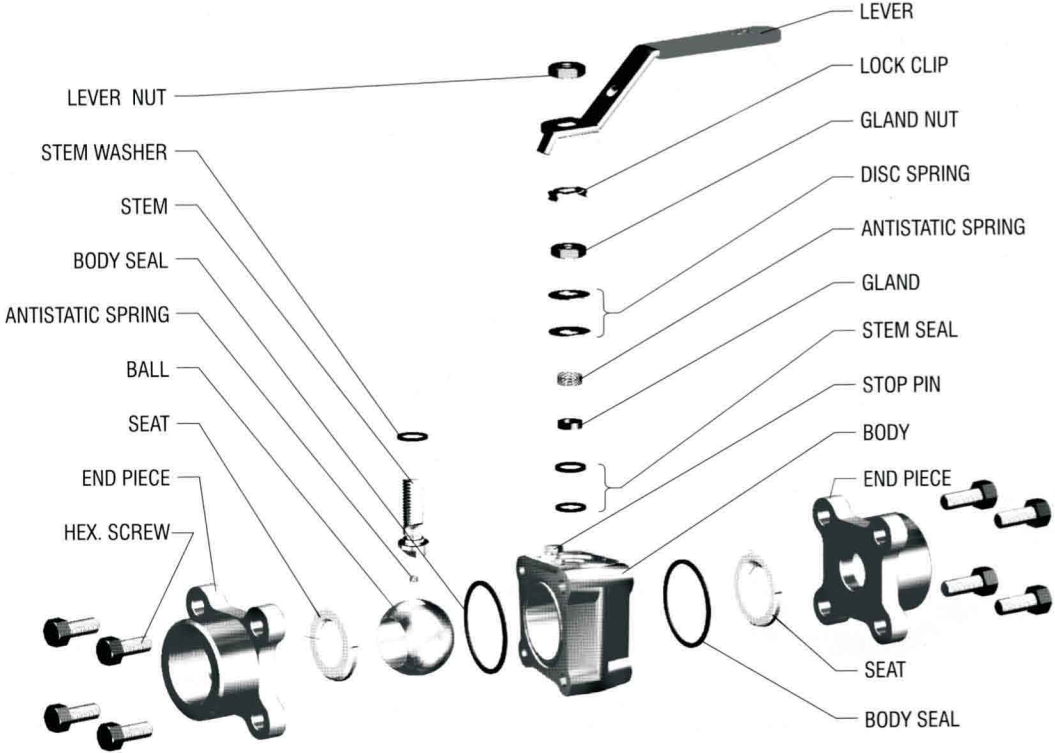

## TWO PIECE

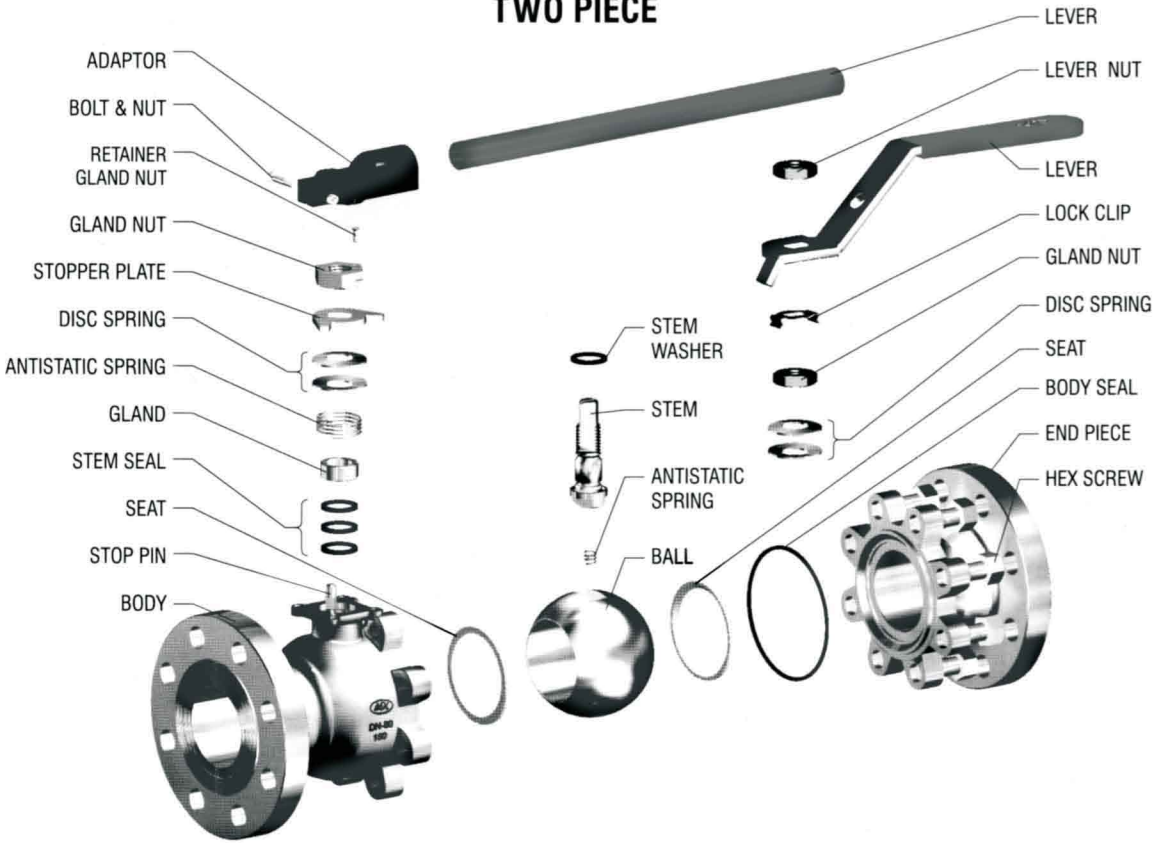

# TWO PIECE, REDUCED & FULL BORE

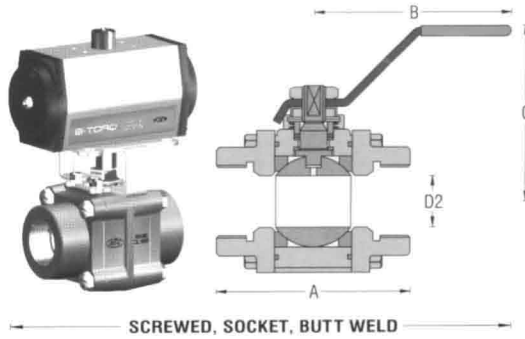

## TEST PRESSURE IN BAR (psi)

SE, SWE & BWE		
Pressure rating	Class 600	Class 800
Hyd. Shell	150 (2176)	207 (3002)
Seat	← 76(1102) →	
Air Seat	← 6.9 (100) →	

## SERIES

'W' R3 / 'W'F3 (Class 600)  
'W' R3 / 'W'F3 (Class 800)

## APPLICATIONS :

- > Chemical Process Plants
- > Fertilizer Plants
- > Dyes and Pigments
- > Pesticides
- > Caustic Chlorine Plants
- > Hazardous Fluids
- > Acids and Alkalies

## RB = REDUCED BORE

## FB = FULL BORE

Dimensions are in mm (inch)

SE, SWE & BWE

SIZE mm (inch)	← A →		← B →		C	d	← D → ← D2 →			
	SE, SWE, BWE RB	FB	RB	FB			RB	RB & FB	RB	FB
8	64	64	120	120	80	-	-	08	08	
(1/4)	(2.5)	(2.5)	(4.7)	(4.7)	(3.1)	-	-	(0.3)	(0.3)	
10	64	64	120	120	80	-	-	11	11	
(3/8)	(2.5)	(2.5)	(4.7)	(4.7)	(3.1)	-	-	(0.4)	(0.4)	
15	64	64	120	120	80	11	13	11	13	
(1/2)	(2.5)	(2.5)	(4.7)	(4.7)	(3.1)	(0.4)	(0.5)	(0.4)	(0.5)	
20	70	75	120	145	85	13	20	13	20	
(3/4)	(2.8)	(3.0)	(4.7)	(5.7)	(3.3)	(0.5)	(0.8)	(0.5)	(0.8)	
25	88	88	145	145	90	20	25	20	25	
(1)	(3.5)	(3.5)	(5.7)	(5.7)	(3.5)	(0.8)	(1.0)	(0.8)	(1.0)	
32	105	105	145	175	105	25	32	25	32	
(1 1/4)	(4.1)	(4.1)	(5.7)	(6.9)	(4.1)	(1.0)	(1.3)	(1.0)	(1.3)	
40	114	114	175	175	110	32	88	32	38	
(1 1/2)	(4.5)	(4.5)	(6.9)	(6.9)	(4.3)	(1.3)	(1.5)	(1.3)	(1.5)	
50	130	145	175	300	135	38	50	38	50	
(2)	(5.1)	(5.7)	(6.9)	(11.8)	(5.3)	(1.5)	(2.0)	(1.5)	(2.0)	

## Materials

Body / End piece	Forged Carbon Steel ASTM A105 / Cast Carbon Steel ASTM A216 Gr. WCB / Stainless Steel ASTM A182 Gr. F304 / F316, ASTM A351 Gr. CF8 / CF8M / CF3 / CF3M / CN7M / Duplex
Ball / Stem	Stainless Steel ASTM A276 A276 Type 410 / 304 / 316 / A20 / Duplex
Seat	PTFE / CFT / GFT / DELRIN / NYLON / PEEK / METAL
Stem Washer	GFT / Grafoil
Stem Seal / Body Seal	Grafoil
Lever	Steel with PVC Sleeve
Body Studs / Nuts	ASTM A193 Gr. B7 / ASTM A194 Gr. 2H
Surface Protection for Carbon	Base Phosphating. Additional External Coating : Smoke Grey Synthetic Enamel
Steel Valves	

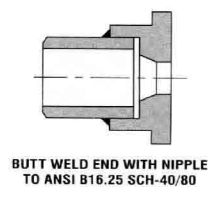
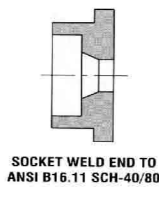
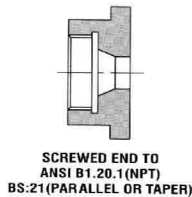

## END DETAILS

- 1) Nett in Kg.(lbs) approx. (without obligation) ■ Valves can be supplied to suit ASME / BS / DIN Flanges. ■ Flanged Ends not available in Forging ■ Valves can be supplied with Pad - lock, Electric, Pneumatic or Gear Actuators and accessories like Limit Switch, Solenoid Valve, Air Filter Regulator etc. ■ Actuator Bracket Mounting as per ISO 5211. ■ Please Specify working Pressure, Temperature & Service conditions. ■ Cavity free (Pocketless) also available. ■ Other materials is not mentioned above available or request.

# TWO PIECE, THREE WAY, REDUCED & FULL BORE

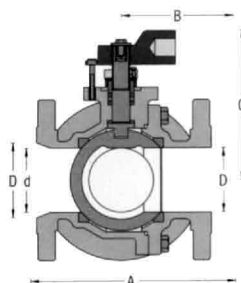

DESIGN STD : BS EN ISO 17292 (BS 5351) TESTING STD : EN 12266-1

Test Pressure in bar (psi)		
Pressure rating	Class 150	Class 300
Hyd. Shell	30 (435)	76 (1102)
Seat	REFER TECHNICAL DATA	
Air Seat	← 6.9 (100) →	

## SERIES

'W' R2-3W / 'W'F2-3W (Class 150)  
'W' R2-3W / 'W'F2-3W (Class 300)

## APPLICATIONS

- > Chemical Process Plants
- > Fertilizer Plants
- > Dyes and Pigments
- > Pesticides
- > Caustic Chlorine Plants
- > Hazardous Fluids
- > Acids and Alkalies

RB = REDUCED BORE

FB = FULL BORE

Dimensions are in mm (inch)

SIZE mm (Inch)	A		B				C	d	D	Wt 1)				
	Class 150 2 SEATS	Class 300 3 SEATS	Class 300 2 & 3 SEATS	RB	FB	RB				FB	Class 150 RB	Class 150 FB	Class 300 RB	Class 300 FB
50 (2)	178 (7.0)	203 (8.0)	216 (8.5)	-	307 (12.1)	-	352 (13.9)	135 (5.3)	-	50 (2)	-	14 (30.9)	-	19 (41.9)
65 (2 1/2)	190 (7.5)	222 (8.7)	241 (9.5)	307 (12.1)	482 (19.0)	352 (13.9)	492 (19.4)	155 (6.1)	50 (2.0)	64 (2.5)	17 (37.5)	24 (52.9)	18 (39.7)	29 (63.9)
80 (3)	203 / 305 <sup>2</sup> (8.0 / 12.0 <sup>2</sup> )	241 (9.5)	283 (11.1)	482 (19.0)	482 (19.0)	492 (19.4)	592 (23.3)	170 (6.7)	58 (2.3)	76 (3.0)	26 (57.3)	29 (63.9)	33 (72.8)	40 (88.2)
100 (4)	229 / 394 <sup>2</sup> (9.0 / 15.5 <sup>2</sup> )	305 (12.0)	305 (12.0)	482 (19.0)	592 (23.3)	592 (23.3)	790 (31.1)	205 (8.1)	76 (3.0)	98 (3.9)	38 (83.8)	50 (110.2)	53 (116.8)	68 (149.9)
150 (6)	267 (10.5)	394 (15.5)	403 (15.9)	592 (23.3)	790 (31.1)	790 (31.1)	★	265 (10.4)	98 (3.9)	152 (6.0)	48 (105.8)	90 (198.4)	91 (200.6)	136 (299.8)
200 (8)	457 (18.0)	457 (18.0)	502 (19.8)	790 (31.1)	★	★	★	★	144 (5.7)	203 (8.0)	100 (220.5)	147 (324.1)	180 (368.8)	190 (418.9)
250 (10)	533 (21.0)	533 (21.0)	568 (22.4)	★	★	★	★	★	187 (7.4)	250 (9.8)	168 (370.4)	240 (529.1)	270 (595.2)	380 (837.8)
300 (12)	610 (24.0)	610 (24.0)	648 (25.5)	★	★	★	★	★	228 (9.0)	300 (11.8)	195 (429.9)	300 (661.4)	350 (771.6)	425 (937.0)

## Materials

Body / End piece	Carbon Steel ASTM A216 Gr. WCB, A352 Gr. LCB, Stainless Steel ASTM A351 Gr. CF8 / CF8M / CF3 / CF3M / CN7M / Duplex
Ball	Stainless Steel ASTM A217 Gr. CA15, A351 Gr. CF8 / CF8M / CN7M / Duplex
Stem / Gland	Stainless Steel ASTM A276 Type 410 / 304 / 316 / Duplex
Seat	PTFE / CFT / GFT / DELRIN / NYLON / PEEK / METAL
Stem Washer	GFT / Grafoil
Stem Seal / Body Seal	Grafoil
Lever	Steel
Body Studs / Nuts	ASTM A193 Gr. B7 / ASTM A194 Gr. 2H
Surface Protection for Steel Valves	Base phosphating. Additional External Coating : Smoke Grey Synthetic Enamel

## FLOW PATTERNS

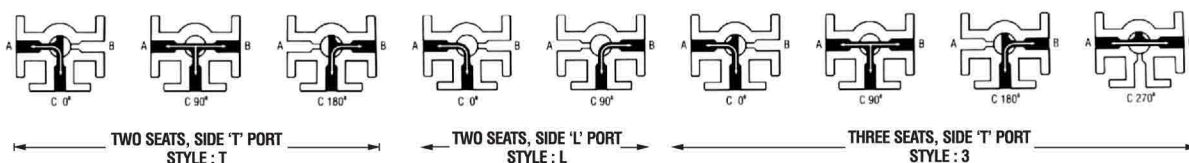

<sup>1</sup>) Nett in Kg. (lbs) approx. (without obligation) ■ 2) Dimension 'A' For FB. ★ Worm Gear operated. ■ Valves can be supplied to suit ASME / BS / DIN Flanges ■ Valves can be supplied with Pad - lock, Electric, Pneumatic or Gear Actuators and accessories like Limit Switch, Solenoid Valve, Air Filter Regulator etc. ■ Actuator Bracket Mounting as per ISO 5211. ■ Please Specify Working Pressure, Temperature & Service conditions. ■ Cavity free (Pocketless) also available. ■ Other materials not mentioned above available on request.

# TRUNNION MOUNTED BALL VALVES

## STANDARDS

DESIGN : API 6D, B5 EN ISO 17292 (BS 5351), ASME B16.34

TESTING : API 6D, API 598, EN 12266-1, ASME B16.34, API 607 / 6FA

## FEATURES

'W'TR = 'W' Series Trunnion Mounted Reduced Bore

'W'TF = 'W' Series Trunnion Mounted Full Bore

'W' TMR = 'W' Series Trunnion Mounted Metal Seat Redced Bore

'W'TMF = 'W' Series Trunnion Mounted Metal Seat Full Bore

## MODELS

- Fire Safe
- Anti Static
- Anti Blow Out
- Double Block & Bleed
- Vent & Drain
- Cavity Pressure Relief
- Spring Loaded Seats
- Sealant Injection
- Fugitive Emission

## SPRING LOADED SEATS

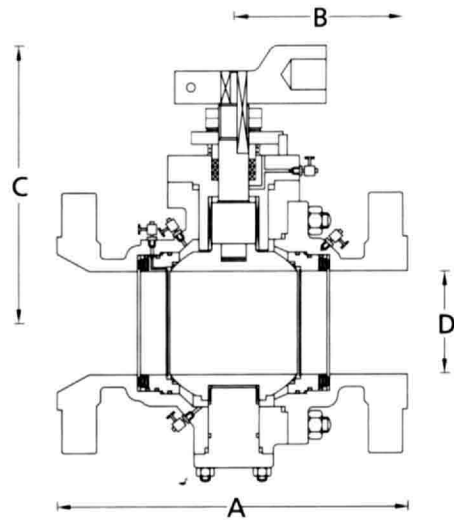
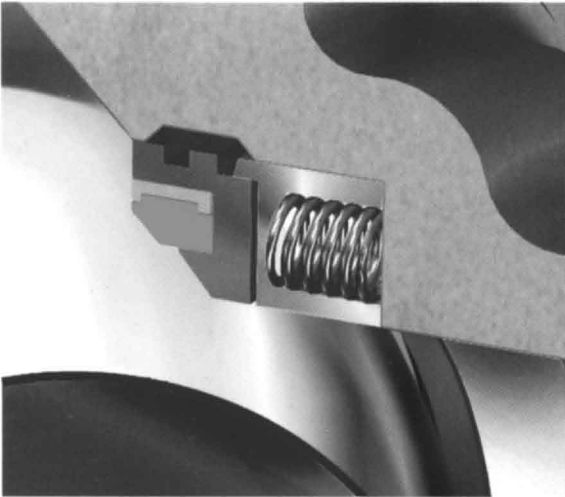

## MATERIALS

Body / End piece	Carbon Steel ASTM A216 Gr. WCB, A352 Gr. LCB, Stainless Steel ASTM A351 Gr. CF8 / CF8M / CN7M / Duplex
Ball	Carbon Steel ASTM A216 Gr. WCB+ENP / StainlessSteel ASTM A217 Gr. CA15 / ASTM A351 GR. CF8 / CF8M / CN7M / Duplex
Stem / Trunnion	Stainless Steel ASTM A564 TYPE 630 (17-4PH) / UNS S31803
Seat / Seat Insert	PTFE / RPTFE / DELRIN / NYLON / PEEK / METAL
Metal Seat	Stainless Steel ASTM A276 Type 410 Hardened / ASTM A276 Type 316 Stellite
Seat Retainer	ASTM A276 Type 410 / A217 Gr. CA15 / A276 Type 316 / A351 Gr. CF8M
Coil Spring	INCONEL X-750
'O' Ring	Viton Gr. B
Stem / Thrust Washer	RPTFE (GFT)
Body Seal	SPIRAL WOUND SS With Graphite filler
Stem Seal	Grafoil
Trunnion / Stuffing Box Seal	PTFE /Grafoil SPIRAL WOUND SS With Graphite filler
Stuffing Box	Carbon Steel ASTM A216 Gr. WCB, A352 Gr. LCB, Stainless Steel ASTM A351 Gr. CF8 / CF8M / CN7M
Stuf. Box & Trunnion Bearing	SS Backed PTFE
Gland Nut	Stainless Steel
Body Stud / Nut	ASTM A193 Gr. B7 / ASTM A194 Gr 2H
Surface Protection for Carbon Steel Valves	Prime cost : Chlorine free with modified alkyd resin unobjectionable in Physiological and Toxicological respects with additional external coating of Machine varnish Smoke Gray

■ Other Materials not mentioned above are available on request.

■ Other Ball Materials with Electro Nickle Plating (ENP) available on request.



Dimensions are in mm (inch)

SIZE mm (inch)	A			B						D		Wt 1)					
	Class 150	Class 300	Class 600	Class 150		Class 300		Class 600		RB/DRB	FB	Class 150		Class 300		Class 600	
	RB	FB	RB	FB	RB	FB	RB	FB	RB/DRB	FB	RB	FB	RB	FB	RB	FB	
50	178	216	292	184	307	184	307	240	602	36/30	49	11	15	15	20	19	25
(2)	(7.0)	(8.5)	(11.5)	(7.2)	(12.1)	(7.2)	(12.1)	(9.4)	(23.7)	(1.4/1.2)	(1.9)	(24)	(33)	(33)	(44)	(42)	(55)
65	190	241	330	307	482	307	502	602	602	49/41	62	18	22	26	34	36	52
(2 1/2)	(7.5)	(9.5)	(13.0)	(12.1)	(19.0)	(12.1)	(19.8)	(23.7)	(23.7)	(1.9/1.6)	(2.4)	(40)	(49)	(57)	(75)	(79)	(115)
80	203	283	356	482	482	502	602	602	625	55/49	75	25	30	38	43	68	90
(3)	(8.0)	(11.1)	(14.0)	(19.0)	(19.0)	(19.8)	(23.7)	(23.7)	(24.6)	(2.2/1.9)	(3.0)	(55)	(66)	(84)	(95)	(150)	(198)
100	229	305	432	482	602	602	★	625	★	74/62	98	34	42	54	76	105	140
(4)	(9.0)	(12.0)	(17.0)	(19.0)	(23.7)	(23.7)	★	(24.6)	★	(2.9/2.4)	(3.9)	(75)	(93)	(119)	(168)	(232)	(309)
150	267 <sup>2)</sup>	403	559	800	★	★	★	★	★	98/74	148	52	90	94	140	190	262
(6)	(10.5)	(15.9)	(22.0)	(31.5)	★	★	★	★	★	(3.9/2.9)	(5.8)	(115)	(198)	(207)	(309)	(419)	(578)
200	292 <sup>2)</sup>	502	660	★	★	★	★	★	★	144/100	198/194 <sup>3)</sup>	100	170	156	225	340	412
(8)	(10.5)	(19.8)	(26.0)	★	★	★	★	★	★	(5.7/3.9)	(7.8/7.6)	(221)	(375)	(345)	(496)	(750)	(908)
250	330 <sup>2)</sup>	568	787	★	★	★	★	★	★	186/151	245/241 <sup>3)</sup>	190	265	250	345	490	635
(10)	(13.0)	(22.4)	(31.0)	★	★	★	★	★	★	(7.3/5.9)	(9.6/9.5)	(419)	(584)	(551)	(761)	(1080)	(1400)
300	356 <sup>2)</sup>	648	838	★	★	★	★	★	★	227/202	295/291 <sup>3)</sup>	290	390	400	490	800	960
(12)	(14.0)	(25.5)	(33.0)	★	★	★	★	★	★	(8.9/8.0)	(11.6/11.5)	(639)	(860)	(882)	(1080)	(1764)	(2116)
350	686	762	889	★	★	★	★	★	★	266/230	325/318 <sup>3)</sup>	430	475	605	665	1045	1325
(14)	(27.0)	(30.0)	(35.0)	★	★	★	★	★	★	(10.4/9.1)	(12.8/12.5)	(948)	(1047)	(1334)	(1466)	(2304)	(2921)
400	762	838	991	★	★	★	★	★	★	305/250	375/365 <sup>3)</sup>	560	775	745	925	1520	(1785)
(16)	(30.0)	(33.0)	(39.0)	★	★	★	★	★	★	(12.0/9.8)	(14.8/14.4)	(1235)	(1709)	(1642)	(2039)	(2756)	(3935)
450	864	914	1093	★	★	★	★	★	★	335/305	430/421	840	925	995	1125	1860	2010
(18)	(34.0)	(36.0)	(43.0)	★	★	★	★	★	★	(13.2/12.0)	(16.9/16.6)	(1852)	(2039)	(2194)	(2480)	(4101)	(4431)
500	915	991	1194	★	★	★	★	★	★	375/335	475/453	960	1015	1335	1555	2150	2300
(20)	(36.0)	(39.0)	(47.0)	★	★	★	★	★	★	(14.8/13.2)	(18.7/17.8)	(2116)	(2238)	(2943)	(3428)	(4740)	(5071)
600	1067	1143	1397	★	★	★	★	★	★	487	589	1025	2050	2450	2800	3250	3900
(24)	(42.00)	(45.0)	(55.0)	★	★	★	★	★	★	(19.2)	(23.2)	(2260)	(4520)	(5401)	(6173)	(7165)	(8568)
750	1295	1397	-	★	★	★	★	-	-	633	735	2000	3200	3020	4100	-	-
(30)	(51.0)	(55.0)	-	★	★	★	★	-	-	(24.9)	(28.9)	(4409)	(7055)	(6658)	(9039)	-	-

Dimensions are in mm (inch)

SIZE mm (inch)	A		B		C		D				Wt 1)			
	Class 900		RB	FB	RB	FB	Class 900		Class 1500		Class 900		Class 1500	
	900	1500	RB	FB	RB	FB	RB/DRB	FB	RB/DRB	FB	RB	FB	RB	FB
50	368	368	550	550	247	450	36/30	49	36/30	49	38	52	38	52
(2)	(14.5)	(14.5)	(21.7)	(21.7)	(9.7)	(17.7)	(1.4/1.2)	(1.9)	(1.4/1.2)	(1.9)	(84)	(115)	(84)	(115)
65	419	419	550	550	425	475	49/41	62	49/41	62	75	90	75	90
(2 1/2)	(16.5)	(16.5)	(21.7)	(21.7)	(16.7)	(18.7)	(1.9/1.6)	(2.4)	(1.9/1.6)	(2.4)	(165)	(198)	(165)	(198)
80	381	470	★	★	450	575	55/49	74	55/49	74	105	145	135	220
(3)	(15.0)	(18.5)	★	★	(17.7)	(22.6)	(2.2/1.9)	(2.9)	(2.2/1.9)	(2.9)	(232)	(320)	(298)	(485)
100	457	546	★	★	457	600	74/62	100	74/62	100	200	250	300	355
(4)	(18.0)	(21.5)	★	★	(18.0)	(23.6)	(2.9/2.4)	(3.9)	(2.9/2.4)	(3.9)	(441)	(551)	(661)	(783)
150	610	705	★	★	575	700	98/74	150	98/74	144	315	395	355	450
(6)	(24.0)	(27.8)	★	★	(22.6)	(27.6)	(3.9/2.9)	(5.9)	(3.9/2.9)	(5.7)	(695)	(871)	(783)	(992)
200	737	832	★	★	680	800	144/100	201	144/100	192	580	685	650	775
(8)	(29.0)	(32.8)	★	★	(26.8)	(31.5)	(5.7/3.9)	(7.9)	(5.7/3.9)	(7.6)	(1279)	(1510)	(1433)	(1708)
250	838	991	★	★	775	900	186/151	252	186/151	239	820	980	890	1125
(10)	(33.0)	(39.0)	★	★	(30.5)	(35.4)	(7.3/5.9)	(9.9)	(7.3/5.9)	(9.4)	(1808)	(2160)	(1962)	(2480)
300	965	1130	★	★	850	1000	227/202	303	227/202	287	1220	1375	1250	1580
(12)	(38.0)	(44.5)	★	★	(33.5)	(39.4)	(8.9/8.0)	(11.9)	(8.9/8.0)	(11.3)	(2690)	(3031)	(2756)	(3483)
350	1050	-	★	★	975	1125	266/230	322	-	-	1490	(1650)	-	-
(14)	(41.3)	-	★	★	(38.4)	(44.3)	(10.4/9.1)	(12.7)	-	-	(3284)	(3638)	-	-
400	1130	-	★	★	1200	1325	305/250	373	-	-	1620	1880	-	-
(16)	(44.5)	-	★	★	(47.2)	(52.2)	(12.0/9.8)	(14.7)	-	-	(3572)	(4145)	-	-

● RB = REDUCED BORE ● DRB = DOUBLE REDUCED BORE ● FB = FULL BORE ★ WORM GEAR OPERATOR

1) Nett in Kg.(lbs) approx, with flanged ends. (without obligation) 2) Long Pattern for Sealant Injection System. 3) Dimension 'D' For Class 600. ● For dimensions 'C' refer sale drgs.  
 ● Flanged Ends according to ASME B16.5; other drillings on request. ● Butt Weld according to ASME B16.25 ● Please Specify Working Pressure, Temperature & Service conditions.  
 ● Valves can be supplied with Padlock, Electric, Pneumatic or Gear Actuators; other accessories like Limit Switch, Solenoid Valve, Air Filter Regulator, Positioner etc.